

Coperchi di svariati tipi, filettati o a baionetta, fino al tipo ribaltabile a 180°, trovano applicazione, insieme ai filtri a cestello, nelle cisterne delle più svariate misure e configurazioni.

I coperchi costruiti in Polipropilene assicurano una ottima resistenza ai raggi U.V. ed una durata pressochè illimitata nel tempo.

Various types of lids, hinged up to 180°, threaded or bayonet lock, can be used, along with the filter baskets, with the largest range of different sizes and configuration of tanks.

The lids are made from U.V. resistant Polypropylene to offer an almost unlimited life.

Tapas de diferentes tipos, roscadas, de bayoneta o incluso abatibles a 180°, pueden aplicarse, junto a los filtros de fondo, en los tanques de las más variadas medidas y configuraciones.

Las tapas están realizadas en Polipropileno resistente a los rayos U.V. para asegurar una duración prácticamente ilimitada en el tiempo.



Coperchio ribaltabile 180° per serbatoi

Coperchio ribaltabile 180° per atomizzatori e gruppi da diserbo completo di anello per fissaggio sul serbatoio.

- Versione con sfiato a labirinto.
- Versione con valvola di sfiato con galleggiante per lavoro su terreni in pendio.
- Disponibili con e senza bloccaggio.
- Disponibili sia con fissaggio laterale che per superfici piane.
- Guarnizione di tenuta sul coperchio di serie.
- **Guarnizione anello da ordinare separatamente.**
- Bloccaggio a baionetta su sei punti per una perfetta chiusura.
- Ribaltamento a 180° per evitare sforzi sul coperchio e sul serbatoio.
- Possibilità di montare la serie di filtri a cestelli in plastica o in acciaio di ns. produzione.

Tank overturning lid 180°

Orchard sprayer overturning lid 180° and crop sprayer groups with tank becket.

- Labyrinth bleed version.
- Air valve with float version to work on sloped ground.
- Available with and without blocking.
- Available with lateral fixing and for flat surfaces.
- Seal on the lid as standard.
- **Ring gasket which must be ordered separately.**
- Bayonet blocking system on six points for perfect lockup.
- 180° turnover to prevent stress on lid and tank.
- Possibility to mount the basket filter series made of plastic or steel of our production.

Tapa abatible 180° para depósito

Tapa abatible 180° para atomizadores y grupos para tratamiento con barras con anillo de fijación al depósito.

- Versión con ventilación en forma de laberinto.
- Versión con válvula de aireación con flotador para trabajos en terrenos en pendiente.
- Disponibles con y sin bloqueo.
- Disponibles ya sea con fijación lateral que para superficies planas.
- Guarnición de estanqueidad en la tapa de serie.
- **Guarnición anular que debe ordenarse por separado.**
- Bloqueo tipo bayoneta en seis puntos para un cierre perfecto.
- Vuelco de 180° para evitar esfuerzos sobre la tapa y sobre el depósito.
- Posibilidad de montar la serie de filtros a cesta de plástico o de acero de nuestra producción.



Versione senza bloccaggio di chiusura
Version without lockup blocking
Versión sin bloqueo de cierre

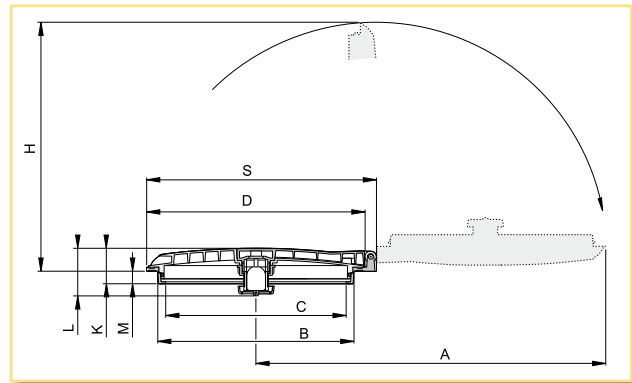

Versione con bloccaggio di chiusura
Version with lockup blocking
Versión con bloqueo de cierre

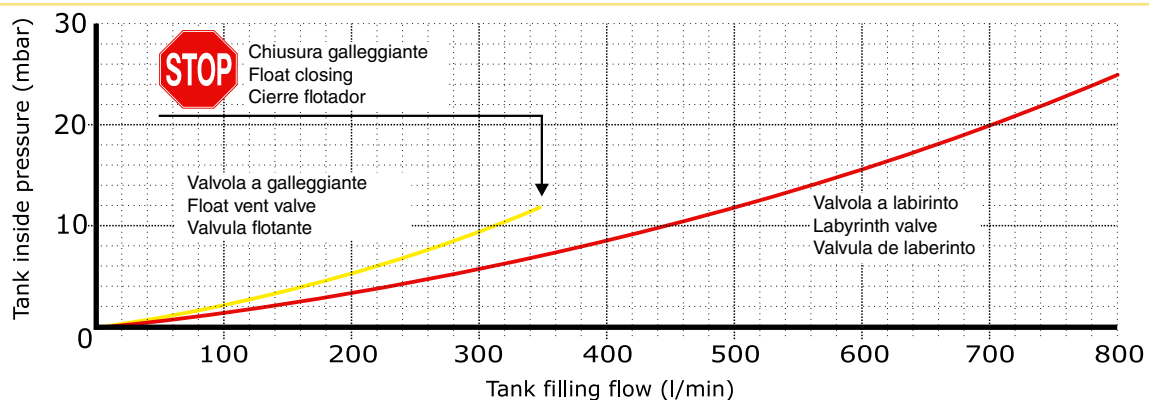
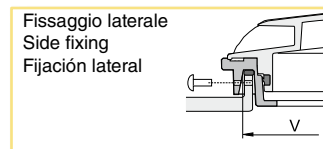
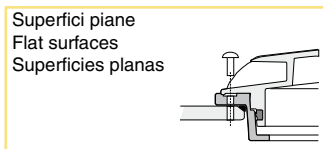
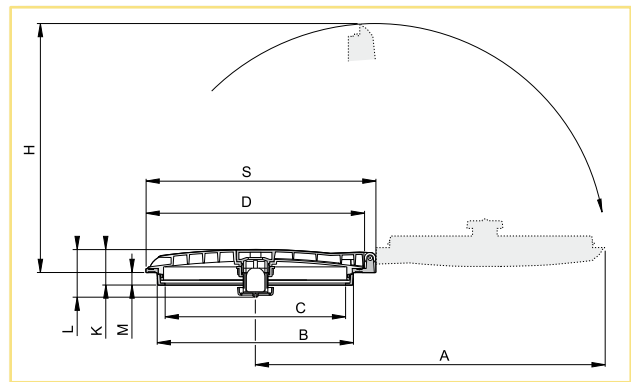

COPERCHI RIBALTABILI
HINGED TANK LIDS
TAPAS ABATIBLES



Sfiato con galleggiante

Float vent valve

Válvula con flotante

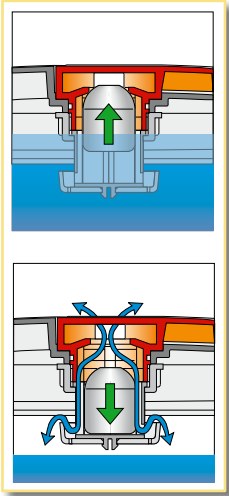

Con bloccaggio
Lockable
Con bloqueo

COD.		D (mm)	B (mm)	C (mm)	I (mm)	L (mm)	M (mm)	H (mm)	S (mm)	A (mm)	V (mm)			
												COD. EPDM	COD.	
356 040		---									---	350 440.020	300 120 300 330	
356 041		●	∅ 367	∅ 320	∅ 290	391	109	26.5	404	390	572			---
356 045		---									336			
356 046		●									336			
356 060		---									---	350 460.020	300 126 300 130 300 134	
356 061		●	∅ 462	∅ 415	∅ 382	486	109	26.5	501	486	713			---
356 065		---									428			
356 066		●									428			

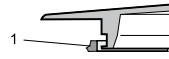

La guarnizione coperchio è già compresa nel codice
The cover gasket is already included in the code
La guarnición de la tapa ya está incluida en el código

Accessori da ordinare separatamente
Accessories to order separately
Accesorios à pedir por separado

Sfiato con labirinto

Labyrinth valve

Válvula con laberinto

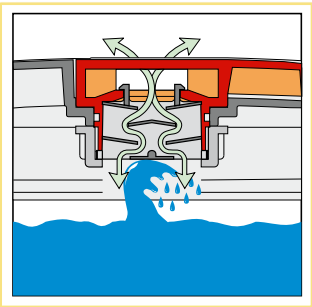

Con bloccaggio
Lockable
Con bloqueo

COD.		D (mm)	B (mm)	C (mm)	I (mm)	L (mm)	M (mm)	H (mm)	S (mm)	A (mm)	V (mm)			
												COD. EPDM	COD.	
356 240		---									---	350 440.020	300 120 300 330	
356 241		●	∅ 367	∅ 320	∅ 290	391	109	26.5	404	390	572			---
356 245		---									336			
356 246		●									336			
356 260		---									---	350 460.020	300 126 300 130 300 134	
356 261		●	∅ 462	∅ 415	∅ 382	486	109	26.5	501	486	713			---
356 265		---									428			
356 266		●									428			

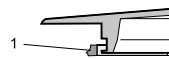

La guarnizione coperchio è già compresa nel codice
The cover gasket is already included in the code
La guarnición de la tapa ya está incluida en el código

Accessori da ordinare separatamente
Accessories to order separately
Accesorios à pedir por separado

Guarniz. di ricambio
Spare gasket
Junta de recambio

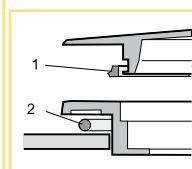

Tipo Type Tipo	COD.	per for para	Materiale Material Material
1	356 640.020NB	∅ 367	NBR
1	356 660.020NB	∅ 462	NBR
2	350 440.020	∅ 367	EPDM
2	350 460.020	∅ 462	EPDM



**fissaggio laterale
side connection
fijación lateral**

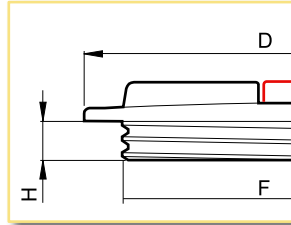

Guarnizione (NBR) tra coperchio e anello (opzionale)
Gasket (NBR) between lid and ring (optional)
Juntas (NBR) entre tapa y aro (opcional)

Diametro Diameter D mm	Kit coperchio + Anello Kit lid + Ring Kit Tapa + Aro	Coperchio Lid Tapa	Anello Ring Aro	F		H mm	Guarnizione* Gasket* Junta*	Filtro Filter Filtro
				mm	inches			
250	351 6221	352 2221	350 2520	210	8.2	31	352 2120.020	300 110 300 116 300 315
355	351 6241	352 2241	350 2540	313	12.3	31	352 2140.020	300 120 300 330
455	351 6261	352 2261	350 2560	410	16.1	25	352 2160.020	300 126 300 130 300 134

**Accessori da ordinare separatamente
Accessories to order separately
Acesorios à pedir por separado**



**superfici piane, con doppia guarnizione
twin gasket ring for flat surfaces
para superficies planas con doble junta**

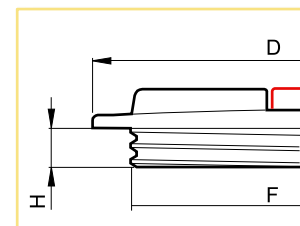

Diametro Diameter D mm	Kit coperchio + Anello Kit lid + Ring Kit Tapa + Aro	Coperchio Lid Tapa	Anello Ring Aro	F		H mm	Filtro Filter Filtro
				mm	inches		
250	351 4221	352 2221	350 620	210	8.2	31	300 110 300 116 300 315
355	351 4241	352 2241	350 640	313	12.3	31	300 120 300 330
455	351 4261	352 2261	350 660	410	16.1	25	300 126 300 130 300 134

**Accessori da ordinare separatamente
Accessories to order separately
Acesorios à pedir por separado**

Coperchio chiuso



Closed lid

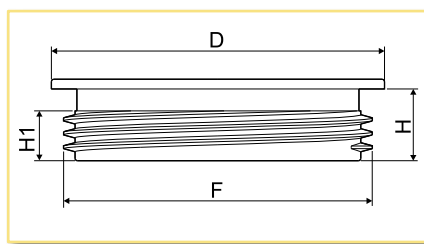

Tapa cerrada

COD.	D (mm)	F (mm)	H (mm)	H1 (mm)
C00 001	137	127	30	21

**ANELLI PER COPERCHI
LID RINGS
AROS PARA TAPAS**

Anello filettato per superfici piane



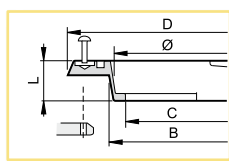

Threaded ring for flat surfaces

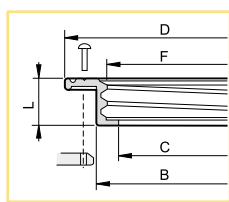

Aro roscado para superficies planas

COD.	D (mm)	Ø (mm) (inches)	B (mm)	C (mm)	L (mm)	 COD.
350 401	159	120 4.7	125	112	17	300 304



COD.	D (mm)	F (mm) (inches)	B (mm)	C (mm)	L (mm)	 COD.
350 2420	255	210 8.2	215	192	38	300 110 300 116 300 315
350 2440	360	313 12.3	320	290	38	300 120 300 330
350 2460	462	410 16.1	415	382	35	300 126 300 130 300 134
350 480	620	567 22.3	575	540	41	---

Anello filettato fissaggio laterale



Threaded ring with side connection

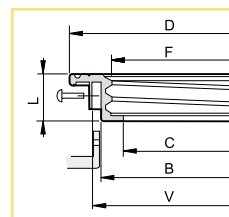

Aro roscado fijación lateral

COD.	D (mm)	F (mm) (inches)	B (mm)	C (mm)	L (mm)	V (mm)	 COD.
350 2520	255	210 8.2	215	192	38	230	300 110 300 116 300 315
350 2540	360	313 12.3	320	290	38	335	300 120 300 330
350 2560	462	410 16.1	415	382	35	430	300 126 300 130 300 134

Guarnizioni di tenuta tra serbatoio e anello

Sealing gaskets between tank and ring

Juntas de sellado entre tanque y aro

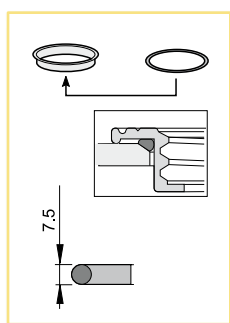

COD.	Per anelli For ring Para aros
350 401.020	350 401
350 420.020	350 2420 350 2520
350 440.020	350 2440 350 2540
350 460.020	350 2460 350 2560
350 480.020	350 480

**COPERCHI
LIDS
TAPAS**



Anello filettato per superfici piane con doppia guarnizione

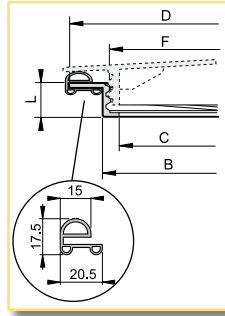

Threaded ring for flat surfaces with double gasket

Aro roscado para superficies planas con doble junta



COD.	D	F		B	C	L	 COD.
	(mm)	(mm)	(inches)	(mm)	(mm)	(mm)	
350 620	255	210	8.2	215	192	38	300 110 300 116 300 315
	350 640	360	313	12.3	320	38	300 120 300 330
	350 660	462	410	16.1	415	35	300 126 300 130 300 134
350 680	620	567	22.3	575	540	41	---

Ricambi
Spare parts
Repuestos

D (mm)	Guarnizione Gasket - Junta 	Anello Ring - Aro 
255	350 620.020	350 2420
355	350 640.020	350 640.010
460	350 660.020	350 660.010
620	350 680.020	350 680.010



**COPERCHI IN GOMMA
RUBBER LIDS
TAPAS DE GOMA**

Coperchio in gomma con valvola di aspirazione

Rubber lids with suction valve

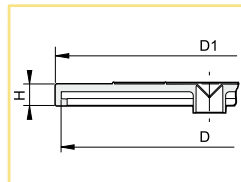
Tapas de goma con válvula de aspiración



COD.	D1	D	H	 COD.	 COD.	 COD.
	(mm)	(mm)	(mm)			
352 420	265	240	15	350 105 350 205	350 420.020	300 112 300 118 300 212 300 320
	352 440	370	360	350 110 350 211	350 440.020	300 120 300 330
	352 460	450	430	22	350 215	350 460.020



COPERCHI FILETTO FEMMINA PER SERBATOI
FEMALE THREADED TANK LIDS
TAPAS DE ROSCA HEMBRA PARA CISTERNAS

354



Coperchio con foro per valvola di sfiato

Lid with hole for breather valve

Tapa con orificio para válvula de respiradero

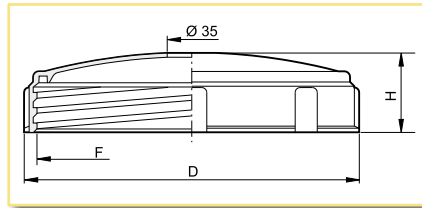

COD.	D (mm)	F (mm)	F (inches)	H (mm)
354 320	240	220	8.6	57

Guarniz. opzionale (EPDM)
 Optional gasket (EPDM)
 Junta opcional (EPDM)

COD.
G 11069

È possibile montare le valvole di sfiato cod. 504 201 o 504 203 (pag. 156)
 This lid can also be fitted with breather valves 504201 or 504203 (page 156)
 Se pueden montar las válvulas de respiradero cód. 504 201 ó 504 203 (pág. 156)

Coperchio con valvola di sfiato a membrana

Lid with diaphragm breather valve

Tapa con membrana de respiradero

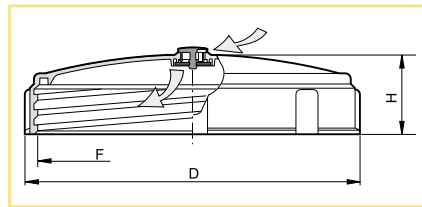

COD.	D (mm)	F (mm)	F (inches)	H (mm)
354 220	240	220	8.6	58.5

Guarniz. opzionale (EPDM)
 Optional gasket (EPDM)
 Junta opcional (EPDM)

COD.
G 11069

Coperchio chiuso

Closed lid

Tapa cerrada

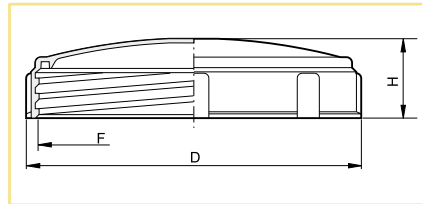

COD.	D (mm)	F (mm)	F (inches)	H (mm)
354 120	240	220	8.6	58.5

Guarniz. opzionale (EPDM)
 Optional gasket (EPDM)
 Junta opcional (EPDM)

COD.
G 11069

Coperchio chiuso "DOT" completo di guarnizione

Closed lid "DOT" with gasket

Tapa cerrada "DOT" con junta

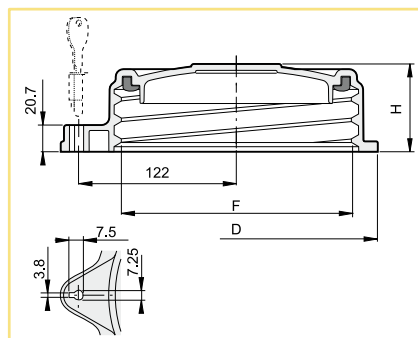

COD.	D (mm)	F (mm)	F (inches)	H (mm)
354 142	219	177	6.9	68

Guarniz. di ricambio (EPDM)
 Spare gasket (EPDM)
 Junta de recambio (EPDM)

COD.
354 040.020

FILTRI IMMISSIONE SERBATOIO
TANK FILLING FILTER
FILTROS LLENADO TANQUES

Coperchi e filtri per pompa a spalla

Lids and filters for back-pack sprayer

Tapas y filtros para equipos de mochila

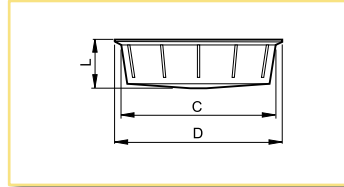
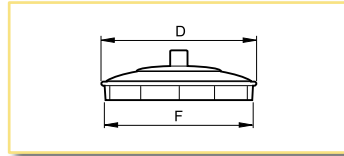

COD.	D (mm)	F (mm)
300 303	90	85
300 305	124	116

COD.	D (mm)	C (mm)	L (mm)
300 302	98	90	31
300 304	118	108	40

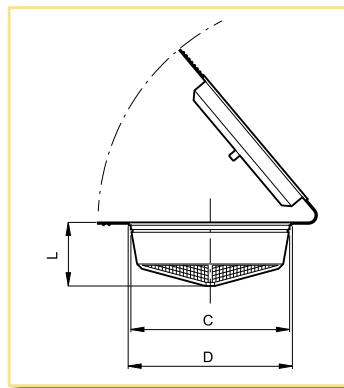

COD.	D (mm)	C (mm)	L (mm)
300 307	112	111	45

Filtro a cestello inox

Stainless steel basket filter

Filtro de cesta inox

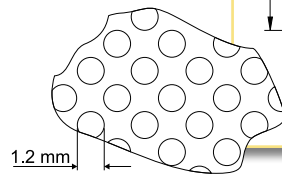
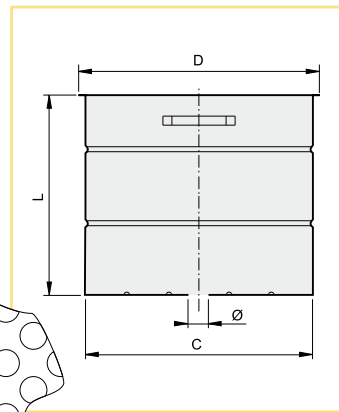

COD.	D (mm)	C (mm)	L (mm)	Ø (mm)
006 950	400	382	160	---
006 960	400	382	333	26



